

```
> restart:with(plots):with(student):
```

```
Warning, the name changecoords has been redefined
```

Maple worksheet for p. 879

p.879 ex. 37

```
> plot3d(y^2+x^2,x=-10..10,y=-10..10,axes = boxed);
```

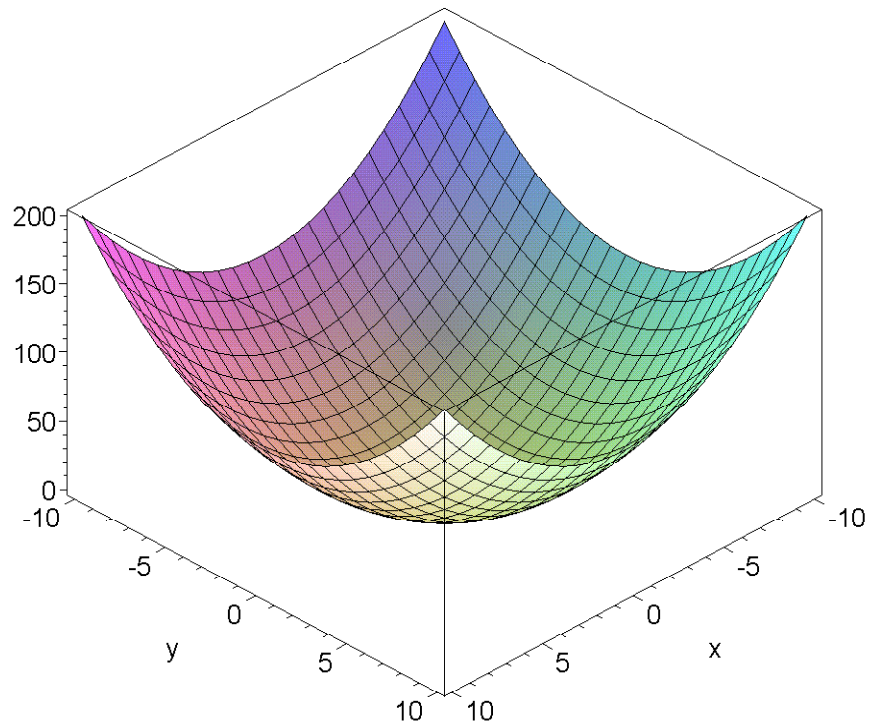

ex 38

```
> plot3d(4*sin(theta),theta=0..2*Pi,z=-1..1, coords=cylindrical,  
style=patch,axes = boxed);
```

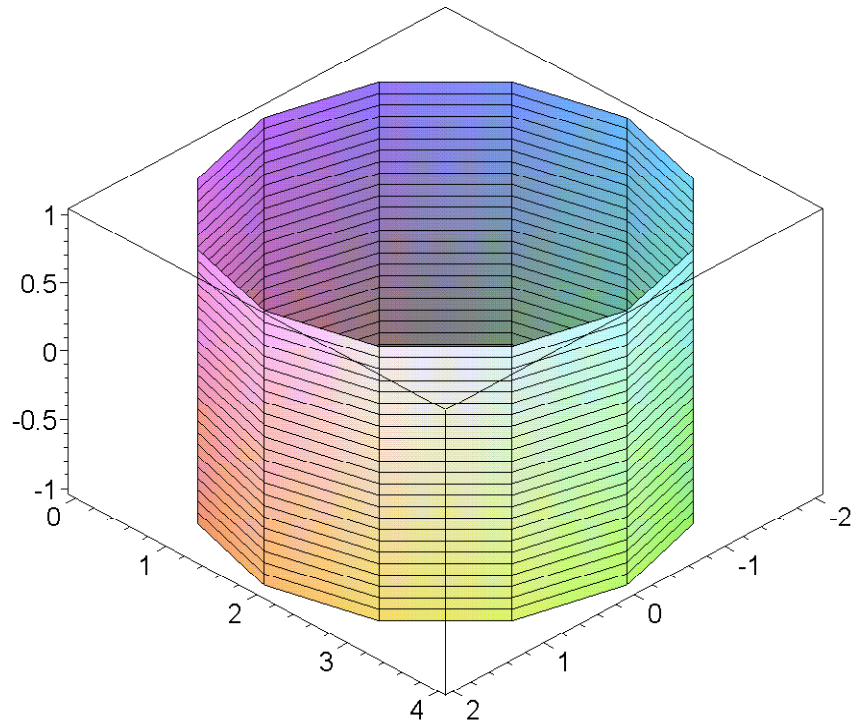

[>

ex 39

```
> plot3d(2/(cos(phi)), theta=0..2*Pi, phi=0..Pi/2,  
  coords=spherical,color = red, axes=boxed);
```

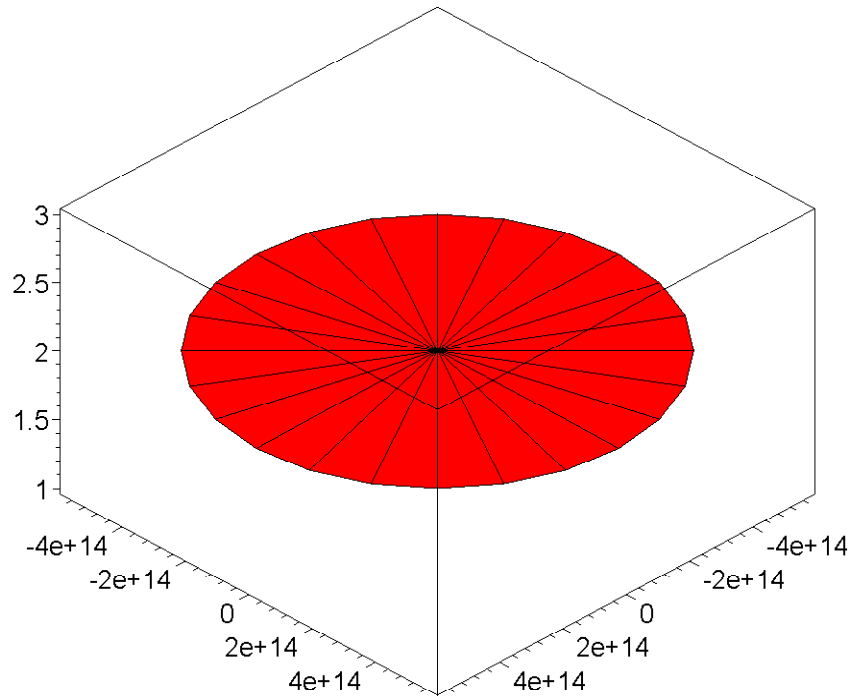

ex 40

```
> plot3d(2/(sin(phi)), theta=0..2*Pi, phi=0..Pi/2,
  coords=spherical,color = red, axes=boxed);
>
```

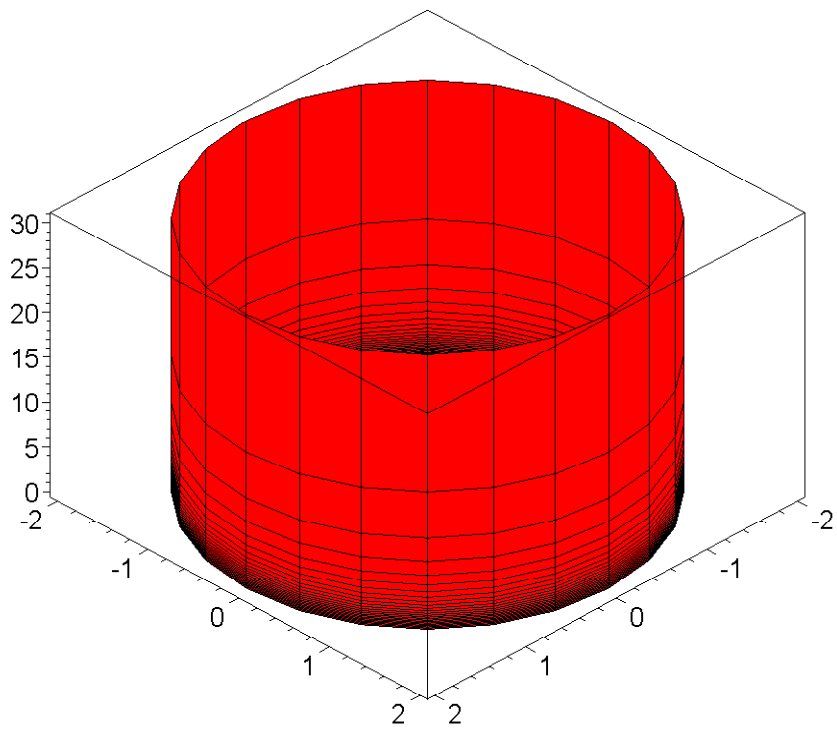

ex 41

```
> plot3d(2*cos(theta),theta=0..2*Pi,z=-1..1, coords=cylindrical,  
style=patch,axes = boxed);
```

>

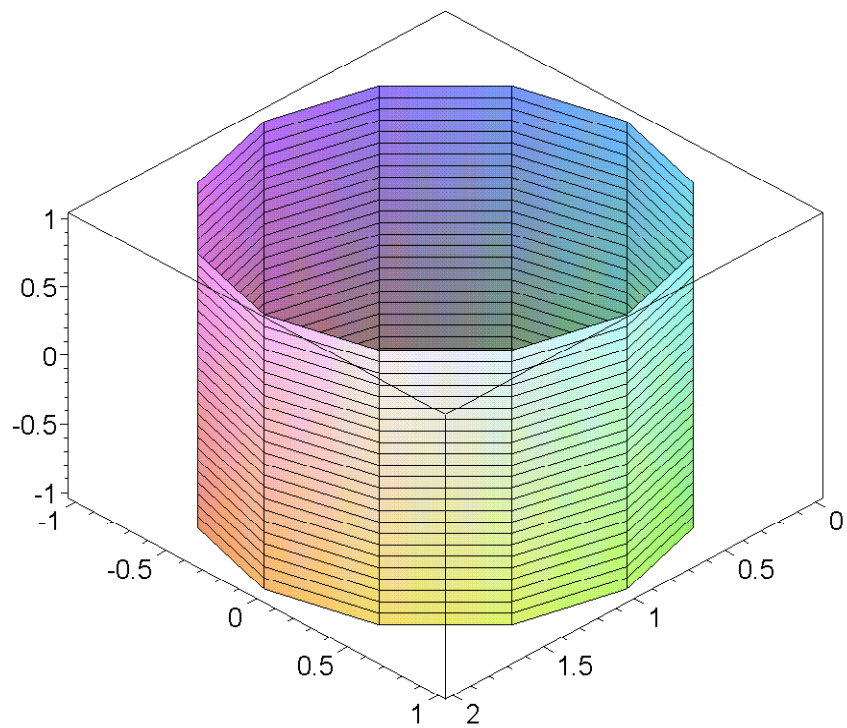

ex 42

```
> plot3d(2*cos(phi),theta=0..2*Pi,phi=0..Pi,coords=spherical,  
style=patch,axes = boxed);
```

>

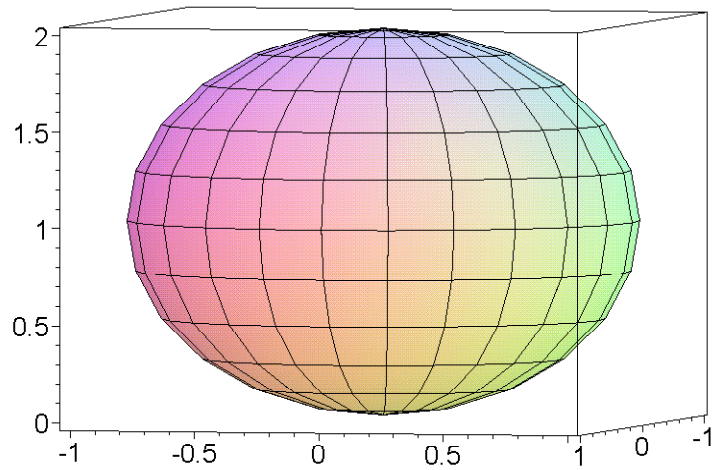

ex 43

```
> plot3d( sqrt(25-z^2),theta=0..2*Pi,z=0..1, coords=cylindrical,  
style=patch,axes = boxed);
```

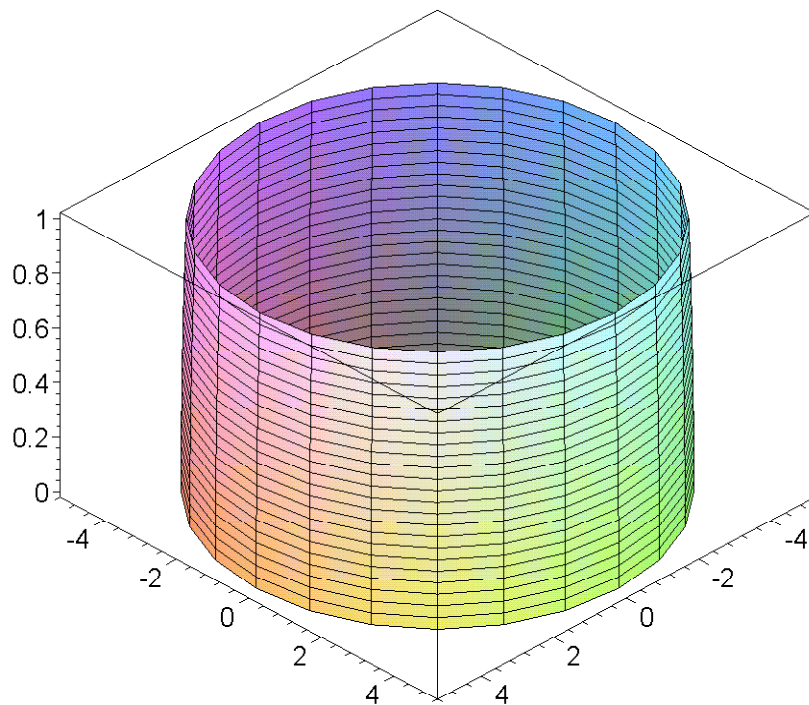

ex 44

```
> plot3d( sqrt(4 + 2*z^2),theta=0..2*Pi,z=0..10, coords=cylindrical,  
style=patch,axes = boxed);
```

>

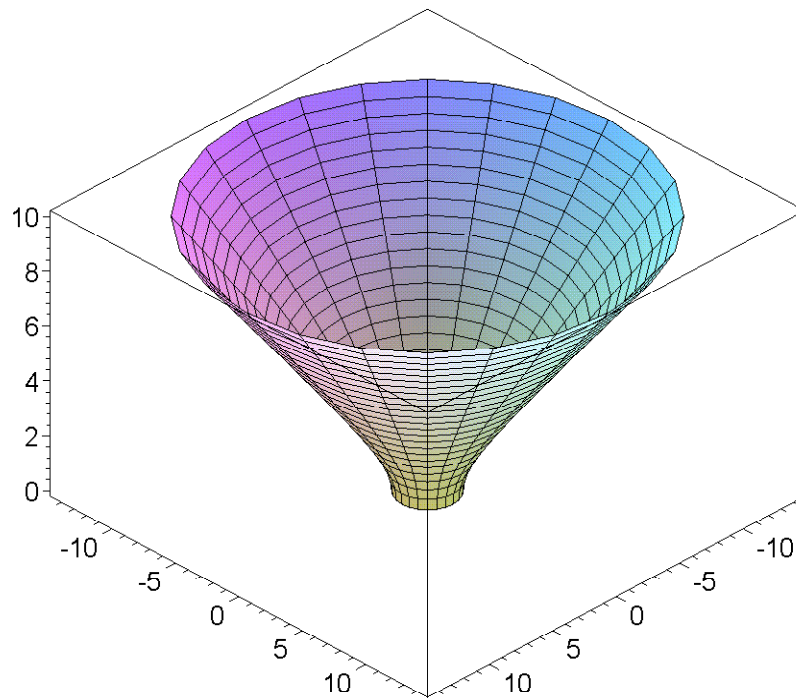

ex 45

```
> implicitplot3d(rho^2*( sin(phi))^2*(cos(theta))^2+  
(cos(phi))^2=1,rho=0..2,theta=0..2*Pi,phi=0..Pi,coords=spherical  
, style=patch,axes = boxed);
```

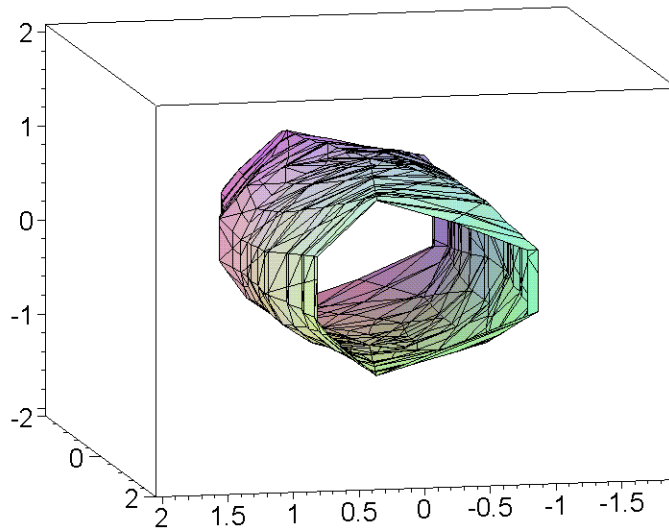

ex 46

```
> plot3d(sqrt(1/( (sin(phi))^2- 4*  
  (cos(phi))^2)),theta=0..2*Pi,phi=0..Pi,coords=spherical ,  
  style=patch,axes = boxed);  
implicitplot3d(rho^2*( (sin(phi))^2- 4* (cos(phi))^2)=1, rho = 0  
  ..10,theta=0..2*Pi,phi=0..Pi,coords=spherical , style=patch,axes =  
  boxed);
```

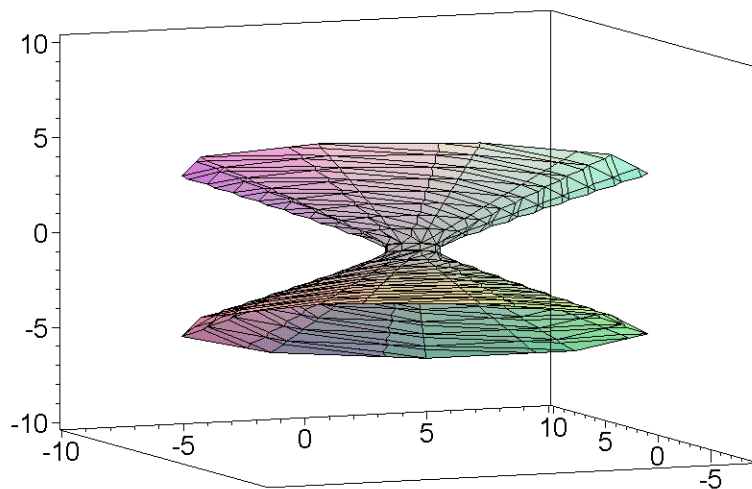
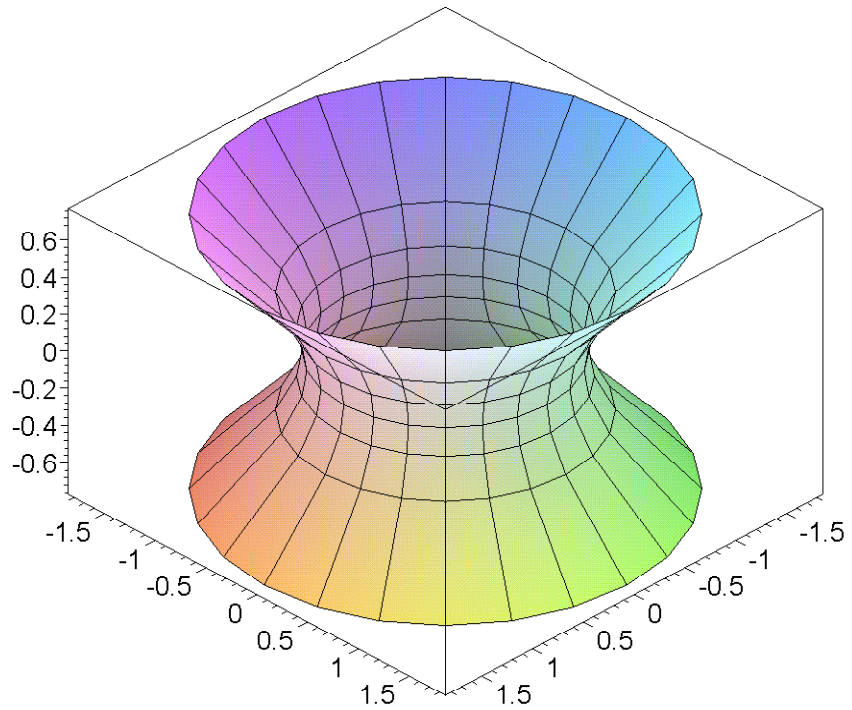
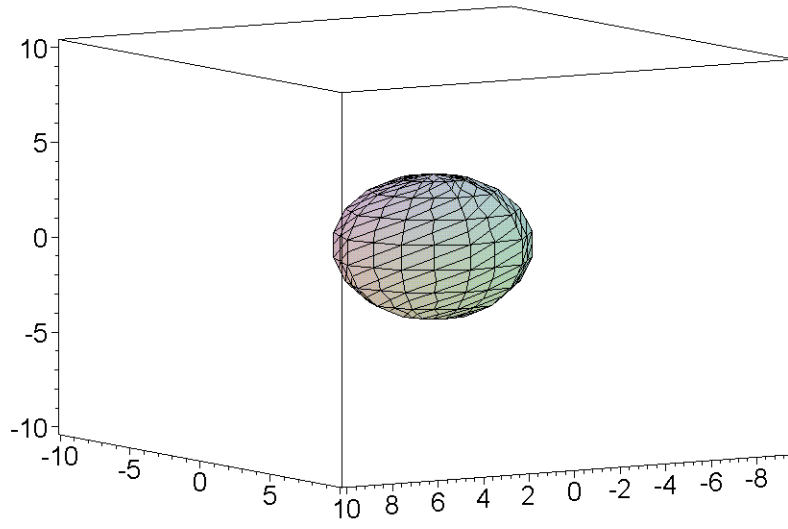
p. 874 ex48

```
> implicitplot3d(rho^2 -6*rho+8=0,rho=0..10,theta=0..2*Pi, phi= 0 ..
  Pi,coords = spherical, axes=boxed);
```

```
>
```

[>